

## Type NS-DC-GR2 Hydraulic Drum Rotator

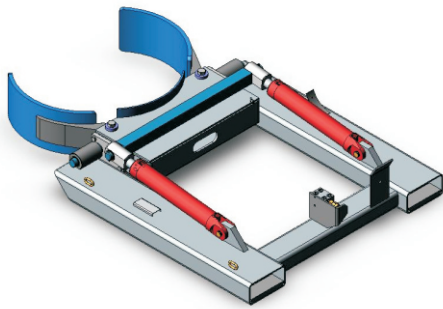

The type NS-DC-GR2 Hydraulic Drum Rotator is a heavy duty 205 litre Drum Lifter with hydraulic grab/rotation ability. With 1 tonne lift capacity, this attachment is ideal for the recycle industry and for mining applications. This lifter is able to pick a single drum from a pallet of 4 without disturbing the other 3 drums.

This unit is fitted with quick connect couplings for connection to the 3rd and 4th Forklift hydraulic valves. The standard finish is painted enamel.

The standard finish is painted enamel.

Type NS-DC-GR2 Hydraulic Drum Rotator	
Product Price :	\$ 5,760.00
Shipping Price	
Sydney	\$ 65.00
Brisbane	\$ 148.00
Melbourne	\$ 113.00
Adelaide	\$ 186.00
Perth	\$ 284.00
*All prices are GST exclusive	

### SPECIFICATIONS:

- Safe Working Load (SWL) 1000kg
- Unit Weight 175kg
- 130° Rotation
- Load Centre 1307.5mm
- Pocket Size 185 x 65
- Pocket Centres 874mm
- Horizontal C of G 700mm

