

## Type NS-DC-GR2/EFD Hydraulic Drum Rotator

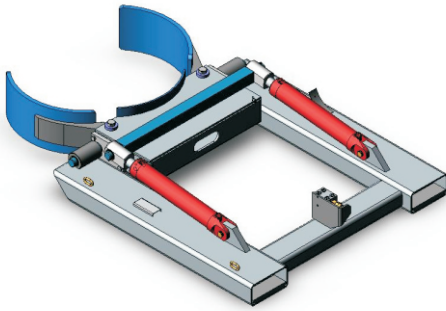

The type NS-DC-GR2/EFD Hydraulic Drum Rotator is a heavy-duty 205 litre Drum Lifter with hydraulic grab/rotation ability. A 12 volt Electric Flow Diverter is fitted for use on Forklifts with only a 3rd hydraulic valve available. This option splits the hydraulic flow to either the grab or rotation functions, eliminating the requirement for the 4th hydraulic valve. To activate the flow diverter the Forklift must be fitted with a push button switch and control wire extending to the carriage.

This lifter is able to pick a single drum from a pallet of 4 without disturbing the other 3 drums.

The standard finish is painted enamel.

Type NS-DC-GR2/EFD Hydraulic Drum Rotator	
Product Price :	\$ 6,460.00
Shipping Price	
Sydney	\$ 65.00
Brisbane	\$ 148.00
Melbourne	\$ 113.00
Adelaide	\$ 186.00
Perth	\$ 284.00
*All prices are GST exclusive	

### SPECIFICATIONS:

- Safe Working Load (SWL) 1000kg
- Unit Weight 180kg
- 130° Rotation
- Load Centre 1307.5mm
- Pocket Size 185 x 65
- Pocket Centres 874mm
- Horizontal C of G 700mm

