

Type DR-NH Drum Rotator with PBO Option

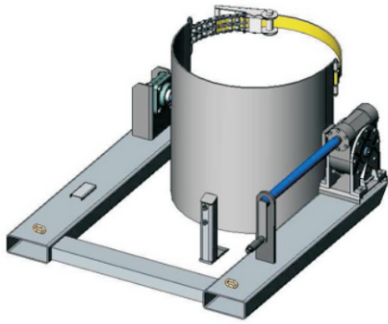

The type NS-DR-NH Drum Rotator with the PBO Cradle fitted is designed to lift and rotate plastic Drums and Barrels as well as 205 litre steel Drums through 360°. Handle rotation of the PBO Cradle via a Gearbox, ensures minimum effort for fully controlled tipping, allowing complete emptying of the Drum/Barrel contents. The dual Woven/Chain combination Belly Straps holds the Drum/Barrel firmly in position.

This slip-on attachment requires only the connection of a safety chain to the Forklift.

The standard finish of this unit is Hot Dip zinc plated.

Type DR-NH Drum Rotator with PBO Option	
Product Price :	\$ 3,212.00
Shipping Price	
Sydney	\$ 65.00
Brisbane	\$ 126.00
Melbourne	\$ 98.00
Adelaide	\$ 156.00
Perth	\$ 235.00
*All prices are GST exclusive	

SPECIFICATIONS:

- Safe Working Load (SWL) 350kg
- Unit Weight 130kg
- 360° Rotation
- Load Centre 940mm
- Pocket Size 165 x 65
- Pocket Centres 820mm
- Horizontal C of G 720mm

