

Type NS-BGN-1 Single Drum Lifter

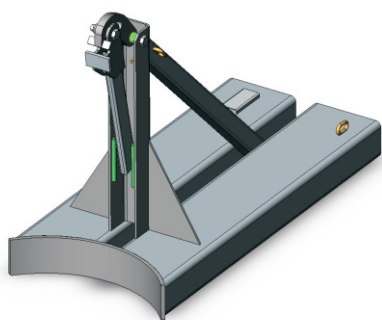

Drum handling made easy. A good field of vision allows the operator to continually observe the drum being handled. The operator does not leave the Driver's seat. The unique beak design provides a high clamping force, even when travelling over uneven ground. With few moving parts this attachment requires no down time for repairs. Suitable for 205 litre steel drums, plastic drums, open top and ring lock drums.

A contoured rest acts at a point low enough down the drum to prevent damage to the drum and its labelling.

SPECIFICATIONS:

- Pocket Size 185 x 60mm
- Pocket Centres 250mm
- Safe Working Load (SWL) 1000kg
- Unit Weight 72kg
- Load Centre 1210mm
- HCG 560mm
- VCG 130mm

Type NS-BGN-1 Single Drum Lifter	
Product Price :	\$ 872.00
Shipping Price	
Sydney	\$ 65.00
Brisbane	\$ 76.00
Melbourne	\$ 64.00
Adelaide	\$ 88.00
Perth	\$ 105.00
*All prices are GST exclusive	

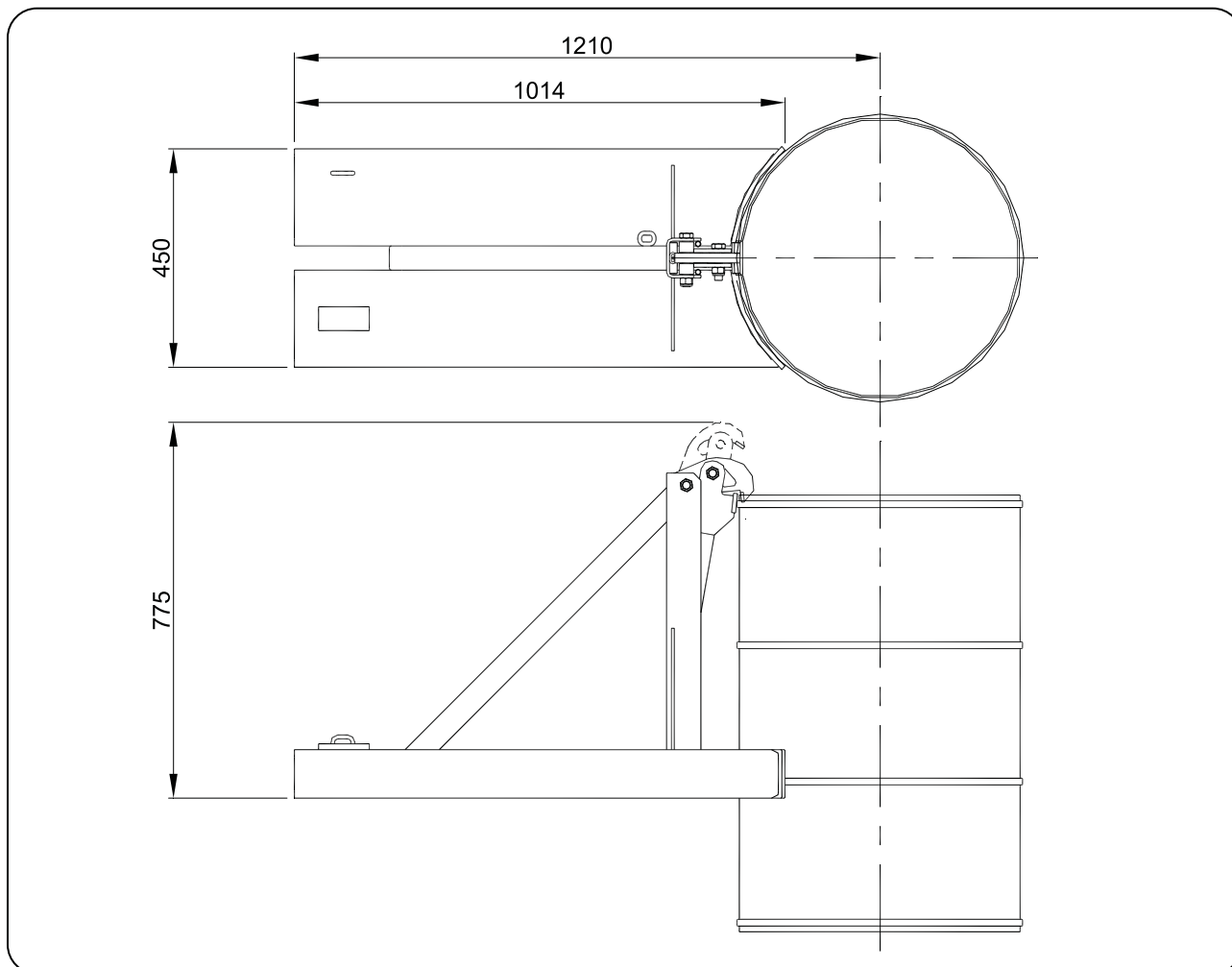

Type NS-BGN-2 Dual Drum Lifter

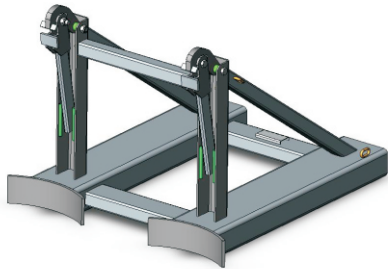

Drum handling made easy. A good field of vision allows the operator to continually observe the drums being handled. The operator does not leave the Driver's seat. The unique beak design provides a high clamping force, even when travelling over uneven ground. The type NS-BGN-2 Dual Drum Lifter has been designed to lift 2 drums side by side or a single drum by either Grab Beak mechanism. With few moving parts, this attachment requires no down time for repairs. Suitable for 205 litre steel drums, plastic drums, open top and ring lock drums.

A contoured rest acts at a point low enough down the drum to prevent damage to the drum and its labelling.

Type NS-BGN-2 Dual Drum Lifter	
Product Price :	\$ 1,280.00
Shipping Price	
Sydney	\$ 65.00
Brisbane	\$ 103.00
Melbourne	\$ 82.00
Adelaide	\$ 125.00
Perth	\$ 183.00
*All prices are GST exclusive	

SPECIFICATIONS:

- Pocket Size 185 x 60mm
- Pocket Centres 600mm
- Safe Working Load (SWL) 1500kg
- Unit Weight 95kg
- Load Centre 1250mm
- HCG 580mm
- VCG 175mm

