

Type NS-SDL1 Drum Lifter

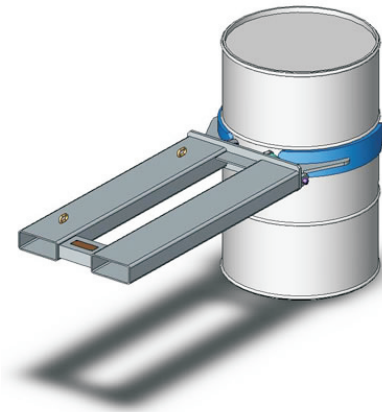

Designed for standard 205 litre steel drums, the fully automatic clamping action enables safe and precise placement of drums without the operator having to leave the Drivers seat. The drum is gripped by pushing the arms against the drum centre and driving forward with the Forklift. The arms will engage around the drum and lock under the rolling hoop when raised. The heavier the load, the tighter the grip becomes. To release the drum, simply lower the drum onto ground level and reverse the Forklift.

The finish on the Drum Lifter is either painted enamel on primed steel or H.D. Galvanised.

Type NS-SDL1 Drum Lifter		
Product Price :	Painted	\$ 1,496.00
	Zinc plated	\$ 1,628.00
Shipping Price		
Sydney		\$ 65.00
Brisbane		\$ 73.00
Melbourne		\$ 62.00
Adelaide		\$ 85.00
Perth		\$ 100.00
*All prices are GST exclusive		

SPECIFICATIONS:

- Pocket Size 165 x 65mm
- Pocket Centres 325mm
- Safe Working Load (SWL) 500kg
- Unit Weight 62kg
- Load Centre 1340mm
- HCG 770mm
- VCG 50mm

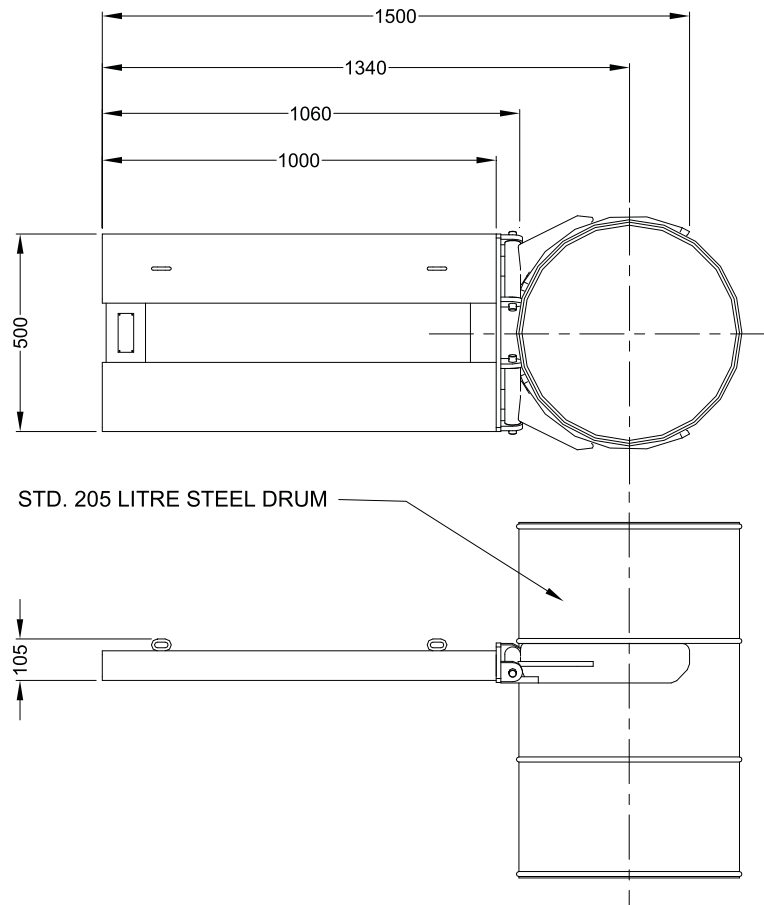

Type NS-SDL2 Dual Drum Lifter

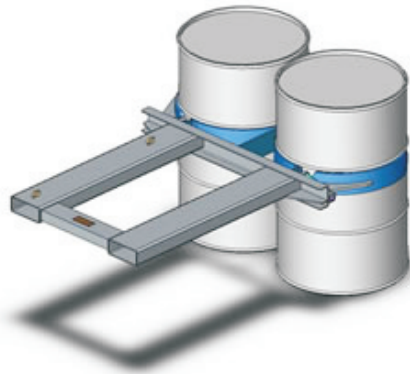

Designed for standard 205 litre steel drums, the fully automatic clamping action enables safe and precise placement of drums without the operator having to leave the Drivers seat. The drum is gripped by pushing the arms against the drum centre and driving forward with the Forklift. The arms will engage around the drum and lock under the rolling hoop when raised. The heavier the load, the tighter the grip becomes. To release the drum, simply lower the drum onto ground level and reverse the Forklift. The type NS-SDL2 Drum Lifter has been designed to lift 2 drums side by side or a single drum by either clamping mechanism.

The finish on the Drum Lifter is either painted enamel on primed steel or H.D. Galvanised.

SPECIFICATIONS:

- Pocket Size 165 x 65mm
- Pocket Centres 585mm
- Safe Working Load (SWL) 1000kg
- Unit Weight 75kg
- Load Centre 1340mm
- HCG 830mm
- VCG 55mm

Type NS-SDL2 Dual Drum Lifter		
Product Price :	Painted	\$ 2,328.00
	Zinc Plated	\$ 2,512.00
Shipping Price		
Sydney		\$ 65.00
Brisbane		\$ 78.00
Melbourne		\$ 65.00
Adelaide		\$ 91.00
Perth		\$ 109.00
*All prices are GST exclusive		

