

## Type NS-TJCL45 Tilt Jib (Long)

The type NS-TJCL45 Tilt Jib (Long) is one of our most versatile Forklift Jib attachments in our range, allowing extra height to 2.23 metres, with a 3.53 metre reach when fully extended. This slip-on attachment is held to the Forklift by a safety chain. The Jibs overall length when closed is 2.1 metres.

The standard finish on this unit is galvanised.

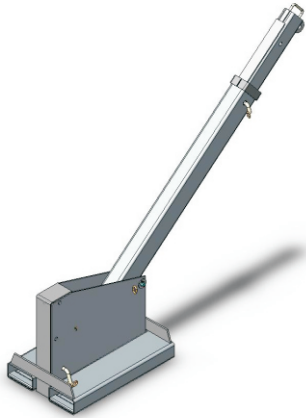

Type NS-TJCL45 Tilt Jib (Long)	
Product Price	\$ 1,539.00
Shipping Price	
Sydney	\$ 65.00
Brisbane	\$ 131.00
Melbourne	\$ 101.00
Adelaide	\$ 163.00
Perth	\$ 205.00
* All Prices are GST exclusive	

### SPECIFICATIONS:

- Safe Working Load (SWL) 4500kg Max.
- Unit Weight 190kg
- Load Centre 770mm
- Pocket Size 185 x 68mm
- Pocket Centres 322 mm
- Horizontal C of G 1080mm
- Vertical C of G 345mm

