

Type NS-XR2-25 Rotator

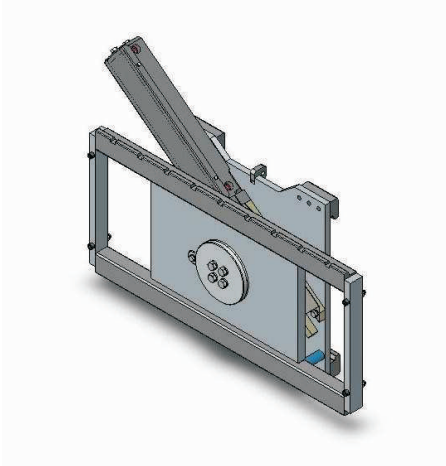

The 180 degree sideways rotator is ideal for load inverting and dumping applications. The NS-XR2-25 Rotator features excellent vision with the operator benefiting from an unimpeded view over the attachment and improved side visibility.

The use of high tensile steel allows low weight with high strength. The single hydraulic cylinder produces smooth, high torque rotation (to the left when seated on the Forklift). Self-lubricating bearings and chrome shafts eliminate maintenance.

The rotation is a precise 180 degrees using the patented Dircks Link Actuator.

SPECIFICATIONS:

- 2500kg at 500mm Load Centre
- Unit Weight 185kg
- Lost Load 153mm
- HCG 80mm
- VCG 294mm
- Class 2 Mounting

