

Type NS-SSD4 Compact Self Dumping Bin

The type NS-SSD4 Compact Self Dumping Bin has been designed with a low profile for confined spaces making it most suitable for the collection of slugs from punch machines. When transporting the bin to the discharge point, the Forklift tines are positioned fully under the bin utilising the Forklifts maximum lift capacity. To tip the bin, the Operator catches the bin on the edge of the bulk container and reverses the Forklift. When the tines clear the pivot point, raising the bin will permit a complete discharge of contents.

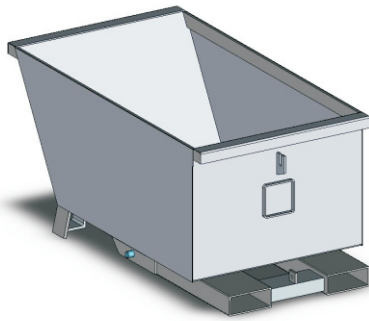

All type NS-SSD bins have been manufactured with a heavy duty construction, have a Safe Working Load of 1000kg and range in sizes from 0.2 – 0.5 cubic metre capacities. These bins are available in either enamel painted over primed steel or H.D. Galvanised finish.

SPECIFICATIONS:

- Pocket size 165 x 65mm
- Pocket Centres – 405mm
- Safe Working Load 1000kg
- Unit Weight – refer Table
- Volume Capacity – refer Table
- HCG & VCG – refer Table

OPTIONS:

- Wheels, Crane Lugs, Lid
- Drain Valve & Strainer

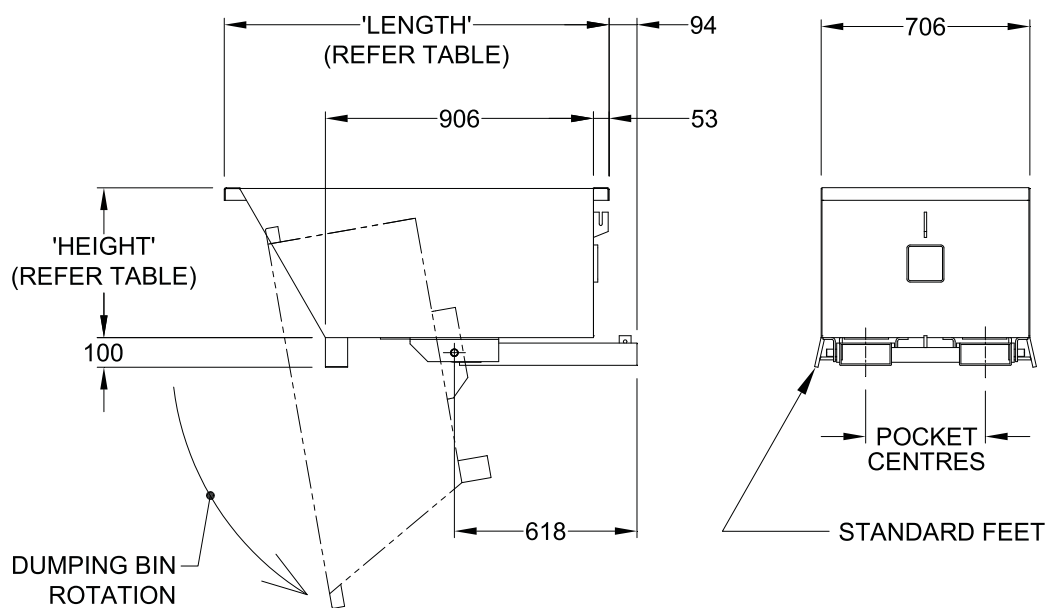

| BIN CAPACITY | CAPACITY | 'HEIGHT' | 'LENGTH' | UNIT WEIGHT | HC of G | V C of G |
|--------------|-----------|----------|----------|-------------|---------|----------|
| NS-SSD3 | 0.20 cu m | 300mm | 1185mm | 80kg | 600mm | 100mm |