

Type NS-NWB-T1 Wheelie Bin Tipper

The type NS-NWB-T1 Wheelie Bin Tipper has been designed for emptying a standard 240 litre plastic bin. The Bin is wheeled into the cradle and secured by the Safety Chain attached to the Backrest allowing the bin to be lifted/transported about the workplace and emptied. The tipping operation is simple and safe with the operator never having to leave his seat.

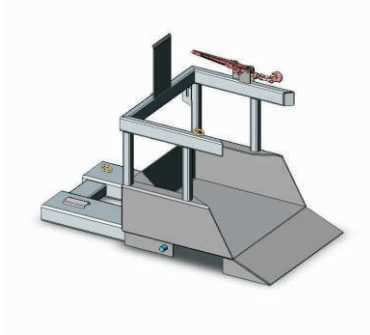

Standard finish on all Wheelie Bin Tippers is painted enamel.

SPECIFICATIONS:

- Safe Working Load (SWL) 500kg
- Load Centre 1200mm
- Unit Weight 100kg
- Pocket Size 165 x 65
- Pocket Centres 340mm
- Capable of 180° Rotation
- Horizontal C of G 720mm
- Vertical C of G 90mm

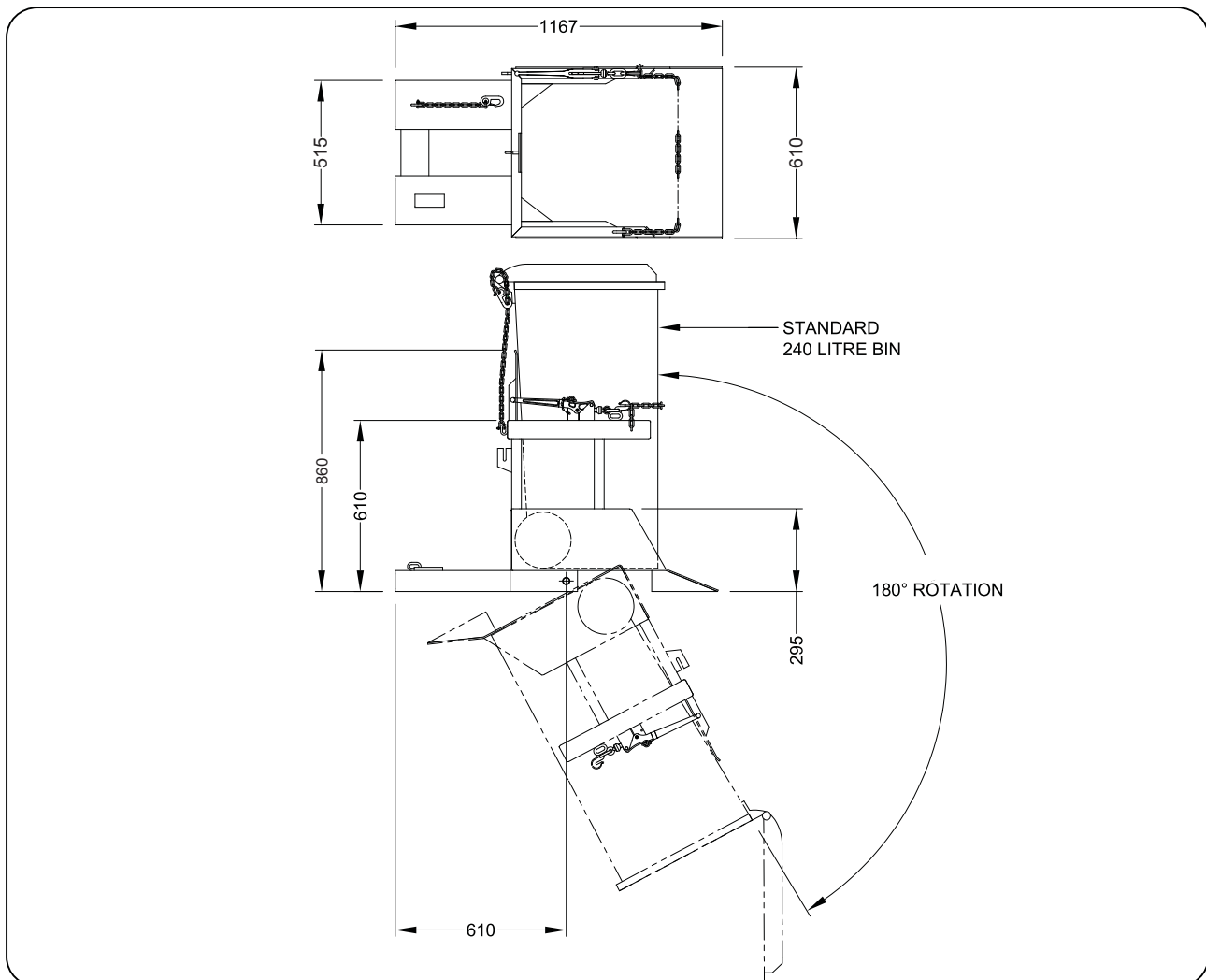

Type NS-NWB-T2 Wheelie Bin Tipper

The type NS-NWB-T2 Wheelie Bin Tipper has been designed for emptying 1 or 2 standard 240 litre plastic bins. The Bins are wheeled into the cradle and secured by the Safety Chains attached to the Backrests allowing the bins to be lifted/transported about the workplace and emptied. The tipping operation is simple and safe with the operator never having to leave his seat.

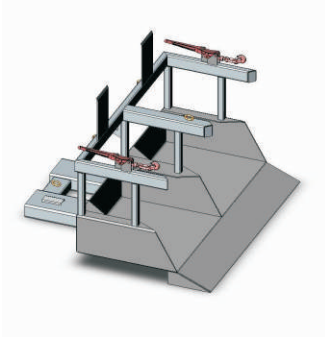

Standard finish on all Wheelie Bin Tippers is painted enamel.

SPECIFICATIONS:

- Safe Working Load (SWL) 1000kg
- Load Centre 1200mm
- Unit Weight 150kg
- Pocket Size 165 x 65
- Pocket Centres 340
- Capable of 180° Rotation
- Horizontal C of G 720mm
- Vertical C of G 90mm

